

QUICK SPECS

Weight (Cabin)	10,792 lbs
Horsepower	39 HP
Max Dig Depth	12'3"

Best performance by your side for the really tough jobs.

YANMAR's ViO50-6A, our 5-ton class mini excavator, is powered by a 39 HP Tier 4 Final YANMAR engine. It comes packed with features to provide high work efficiency and operator comfort while working on tough construction job sites. With true zero tail swing, it allows you to be more productive to trench and dig with low total cost of ownership. Plus, YANMAR's unique SmartAssist Remote gives you peace of mind with theft prevention and maintenance management tools as well as other remote monitoring services.

INNOVATIVE FEATURES



True Zero Tail Swing

Our true zero tail swing technology means no part of the housing extends beyond the tracks. Since the entire machine operates within its tracks, you can work efficiently almost anywhere, with less damage to the machine and the worksite.



YANMAR's Patented Hydraulic Quick Coupler

The standard hydraulic quick coupler makes changing buckets fast and easy. With the exception of fitting and removing the safety lock pin, the entire operation is performed electronically while you're seated in the comfort of the cab. Less hassle. Less downtime. More productivity.



A Cab With Everything At Your Fingertips

The ViO50-6A comes standard with ECO Mode, Auto-Decel Mode, lever-controlled backfill blade and 2-speed operation incorporated right into the operator's station. Plus, you get an innovative LCD monitor, showing key operating information and maintenance notification intervals.



ViO50-6A

**POWERFUL, EFFICIENT
39 HP TIER 4 FINAL
YANMAR DIESEL ENGINE**

**VIO PROGRESSIVE
3-PUMP HYDRAULIC
SYSTEM (VIPPS)**

**EASY-TO-OPERATE
JOYSTICK CONTROLS
WITH ARMRESTS
REDUCE OPERATOR
FATIGUE**

**SPRING STEEL
CYLINDER ROD GUARDS
AND HOSE PROTECTION**

**4-PILLAR ROPS/FOPS
CANOPY FOR SAFETY**

**INTEGRATED BOOM
LIGHT PROTECTS FROM
DAMAGE**

**EASY MAINTENANCE
ACCESS TO EVERY
MAJOR COMPONENT**

**ANGLED CRAWLER
FRAME REDUCES
FOREIGN MATTER
BUILD-UP**

**OPTIONAL PTO2
CIRCUIT AVAILABLE**

**OPTIONAL ENCLOSED
CAB WITH HEAT & A/C**

**ANGLE BLADE OPTION
AVAILABLE**



ViO50-6A

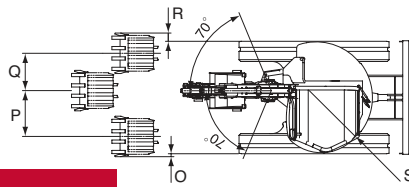

Dimensions - ViO50-6A

A 11'8" (3,550 mm)	K 1'8" (500 mm)
B 12'3" (3,740 mm)	L 6'4.5" (1,940 mm)
C 7'10" (2,380 mm)	M 1'2" (350 mm)
D 18'10" (5,740 mm)	N 1'1.6" (345 mm)
E 17'5" (5,320 mm)	O 1.5" (35)
F 8'6" (2,590 mm)	P 2'3" (680 mm)
G 18'8" (5,700 mm)	Q 2'6" (770 mm)
H 12'1" (3,680 mm)	R 5" (125 mm)
I 7'10" (2,380 mm)	S R3'2" (R970 mm)
J 8'4" (2,540 mm)	

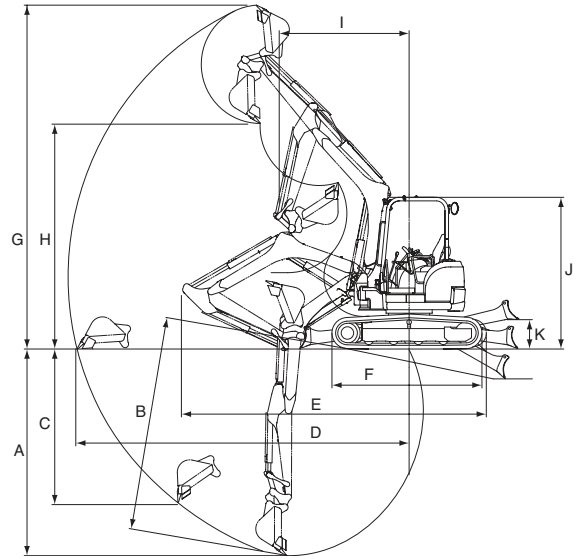
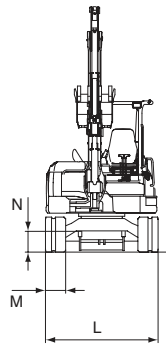

Specifications

Model			ViO50-6A	
Type			Canopy	Cabin
Operating Weight	Rubber Track	lbs (t)	10,417 (4.73)	10,792 (4.90)
	Steel Track	lbs (t)	10,703 (4.86)	11,078 (5.03)
Engine	Type	-	Vertical 4-cylinder water-cooled direct injection diesel engine	
	Model	-	YANMAR 4TNV88C-PBV	
	Output	HP (kW)/rpm	39 (29.1) / 2,400	
Performance	Max Digging Force, Bucket / Arm	lbs (kN)	8,206 (36.5)* / 5,103 (22.7)*	
	Traveling Speed, High / Low	MPH (km / h)	2.9 / 1.5 (4.6 / 2.4)	
	Swing Speed	RPM	10	
	Boom Swing Angle, (L / R)	degrees	68° / 68°	
Ground Contact Pressure	Rubber Track	PSI (kPa)	4.25 (29.3)	4.41 (30.4)
	Steel Track	PSI (kPa)	4.42 (30.5)	4.58 (31.6)
Hydraulic System	Pump Capacity	GPM (L / min)	11.2 + 11.2 + 9.7 + 2.8 (42.5 + 42.5 + 37 + 10.8)	
	Main Relief Set Pressure	PSI (MPa)	3553 x 2 + 3133 + 566 (24.5 x 2 + 21.6 + 3.9)	
Undercarriage	Track Type	-	Rubber or Steel	
Blade Dimensions	Width x Height	ft-in (mm)	6'6" x 14" (1,970 x 400)	
Fuel tank capacity		Gals (L)	17.4 (66)	

*without quick coupler

Standard Equipment

- Blade
- Boom Swing
- Rubber Tracks
- Hydraulic Quick Coupler*
- 2-way Pattern Control
- Arm End Auxiliary Valve
- Cylinder Rod Guards (boom, arm, bucket, blade)
- ROPS / FOPS Cabin or Canopy
- Windshield Washer (cabin spec)
- Defroster (cabin spec)
- Joystick Pilot Controls
- Arm Rests (adjustable)
- Suspension and Reclining Seat
- Seat Belt
- Traveling Levers and Pedals
- Traveling Alarm
- Built-in Boom Light
- Exterior Canopy or Cabin Work Light
- Operation Manual

*Also available without Quick Coupler.

Please note that the standard equipment may vary from this list. Consult your YANMAR dealer for confirmation.

Hydraulic PTO

Model		ViO50-6A		
Specification	Output	PSI (MPa)	GPM (L / min)	
			2,200RPM	1,200RPM
Combined Flow, Double Actions		3,553 (24.5)	20.9 (79.5)	11.4 (43.4)

Lifting Capacity

LIFT POINT HEIGHT in (mm)	(R) LIFT RADIUS in (mm)											
	RATED LIFT CAPACITY OVER END BLADE DOWN				RATED LIFT CAPACITY OVER END BLADE UP				RATED LIFT CAPACITY OVER SIDE BLADE DOWN			
	lbs (kg)				lbs (kg)				lbs (kg)			
157.5 (4,000)	MAX	157.5 (4,000)	118.1 (3,000)	78.7 (2,000)	MAX	157.5 (4,000)	118.1 (3,000)	78.7 (2,000)	MAX	157.5 (4,000)	118.1 (3,000)	78.7 (2,000)
118.1 (3,000)	2,403 (1,090)	2,358 (1,070)	2,314 (1,050)		2,290 (1,040)	1,543 (700)	1,829 (830)		1,763 (800)			
78.7 (2,000)	2,425 (1,100)	2,645 (1,200)	3,306 (1,500)		1,300 (590)	1,719 (780)	3,152 (1,430)		1,146 (520)	1,587 (720)	2,425 (1,100)	
39.4 (1,000)	2,535 (1,150)	3,042 (1,380)	4,365 (1,980)		1,256 (570)	1,675 (760)	2,535 (1,150)		1,124 (510)	1,499 (680)	2,204 (1,000)	
Ground (0)	2,579 (1,170)	3,284 (1,490)	4,585 (2,080)	6,459 (2,930)	1,300 (590)	1,587 (720)	2,358 (1,070)	4,166 (1,890)	1,102 (500)	1,366 (620)	2,028 (920)	3,351 (1,520)
-39.4 (-1,000)	2,667 (1,210)	2,910 (1,320)	4,232 (1,920)	6,393 (2,900)	1,521 (690)	1,587 (720)	2,403 (1,090)	4,387 (1,990)	1,322 (600)	1,344 (610)	1,984 (900)	3,571 (1,620)
-78.7 (-2,000)	2,535 (1,150)		2,954 (1,340)		2,601 (1,180)		2,469 (1,120)		1,940 (880)		2,116 (960)	