

# ML12C/ML18C/ML24C

## MATERIAL LIFTS

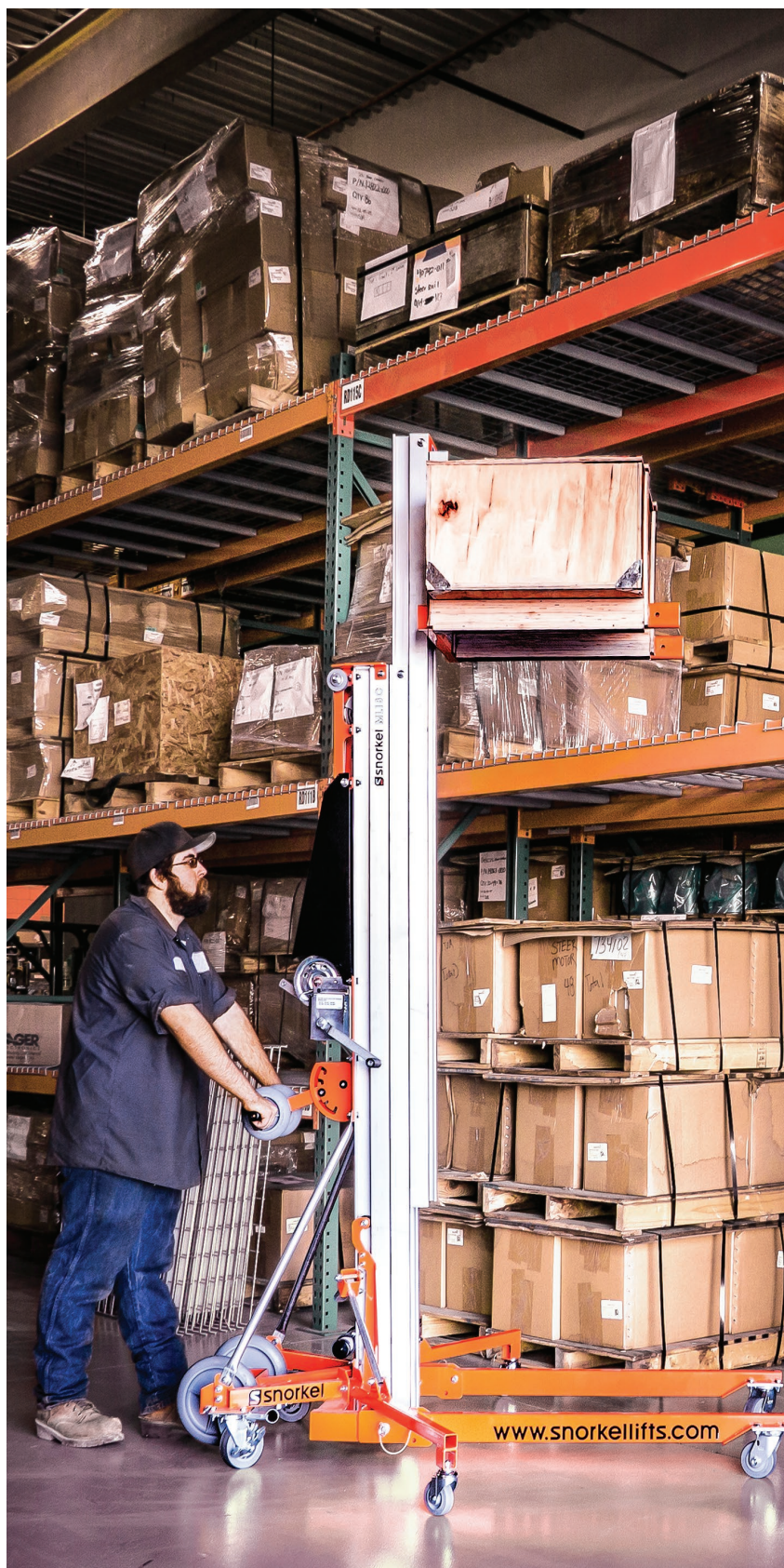

- A high specification material lift, with best-in-class load capacity
- Can pass through a standard doorway
- Robust and reliable
- Features a dual handle, shift-on-the-fly, two-speed winch for improved productivity

 **snorkel**™  
[www.snorkellifts.com](http://www.snorkellifts.com)

# MATERIAL LIFTS ML12C/ML18C/ML24C

DIMENSIONS	ML12C	ML18C	ML24C
Lift height – forks up	13 ft 3 in	18 ft 6 in	24 ft 4 in
Lift height – forks down	11 ft 6 in	16 ft 10 in	22 ft 7 in
Stowed width <b>(A)</b>	30.5 in	30.5 in	30.5 in
Stabilizer width <b>(B)</b>	64 in	64 in	64 in
Stowed length <b>(C)</b>	2 ft 9 in	2 ft 9 in	2 ft 9 in
Operating length	5 ft 2 in	6 ft 1 in	6 ft 9 in
Stowed height <b>(D)</b>	7 ft 2 in	7 ft 2 in	7 ft 2 in
Fork width (outside)	23 in	23 in	23 in
Fork length <b>(E)</b>	30 in	30 in	30 in
Ground clearance	2.5 in	2.5 in	2.5 in

PERFORMANCE			
Max. load capacity (14 in. load center)	750 lbs	700 lbs	650 lbs
Max. load capacity (24 in. load center)	450 lbs	440 lbs	430 lbs
Max. load capacity (42 in. load center)	200 lbs	185 lbs	175 lbs
Min. load height	6 in	6 in	6 in
Winch (high speed)		4 cranks/ft	
Winch (low speed)		15 cranks/ft	

WEIGHT			
Weight	245 lbs	310 lbs	358 lbs

## LOAD CAPACITY - STANDARD FORKS

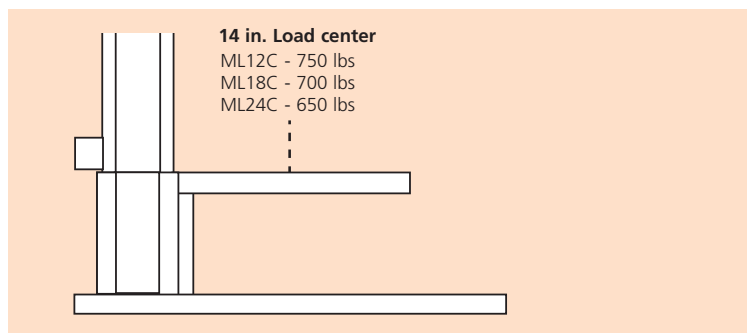

## LOAD CAPACITY - EXTENDED FORKS

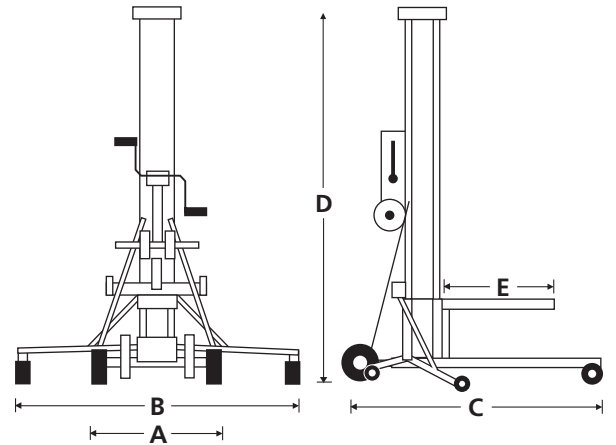
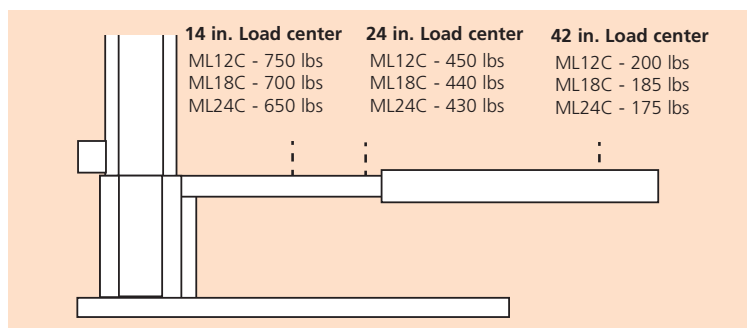

## STANDARD FEATURES

- Stabilizers with non-marking swivel casters (ML18C & ML24C)
- Mast brake
- Cable guard
- Smart latch system
- Non-marking transport/loading wheels
- Dual handle, two-speed shift-on-the-fly winch
- Metal cable pulleys with sealed bearings
- Heavy gauge aluminum extrusions
- Heavy duty, non-marking casters
- Quick-fold stabilizers
- Crane attachment point
- 2 year parts & labor, 5 year structural warranty
- ANSI compliant

## OPTIONS

- Special paint colors
- Adjustable forks
- Fork extensions
- Boom
- Pipe cradle
- Load platform
- Stabilizers with non-marking swivel casters (ML12C)



P.O. Box 1160  
 St. Joseph, MO 64502-1160, USA  
 Tel: 1 (785) 989-3000  
 Toll-free: 1 (800) 255-0317  
 Fax: 1 (785) 989-3070  
 Email: sales.usa@snorkellifts.com

www.snorkellifts.com