

S3210P

PUSH-AROUND MINI SCISSOR LIFT



- Outdoor-rated
- Simple to use; easy to maintain
- No stabilizers required
- Durable design for tough site conditions
- Proven benefits over other low level access products

 **snorkel**[™]
www.snorkellifts.com

PUSH-AROUND MINI SCISSOR LIFT

S3210P

DIMENSIONS	S3210P*
Max. working height	15 ft 10 in
Max. platform height (A)	9 ft 10 in
Platform size (outside)	43 in x 20 in
Overall width (B)	2 ft 8 in
Overall length (C)	3 ft 11 in
Stowed height (D)	5 ft 10 in

PERFORMANCE	
Platform capacity (SWL)	529 lbs
Max. wind speed	28 mph
Raise/lower time	19/26 sec

POWER	
Power source	12V DC battery
Battery charger	Built in multi-voltage (90V - 240V)

WEIGHT	
Weight	1,036 lbs

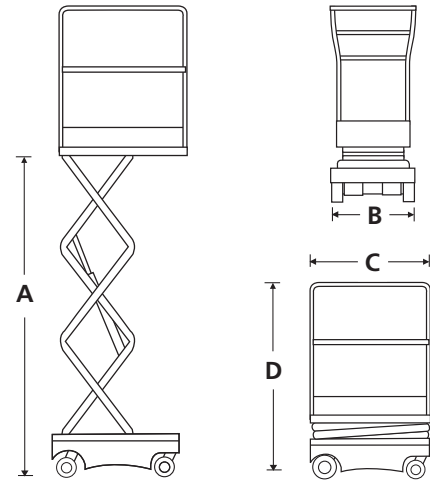

STANDARD FEATURES

- Outdoor-rated
- Auto brake system
- Tilt sensor
- Saloon-door style entry gates
- Integrated battery charger 90V - 240V
- Battery charge indicator
- Forklift pockets
- Emergency lowering system
- Non-marking casters
- Slide-out service trays
- 2 year parts & labor, 5 year structural warranty
- ANSI compliant

OPTIONS

- Special paint colors
- Environmental hydraulic oil

PLATFORM HEIGHT

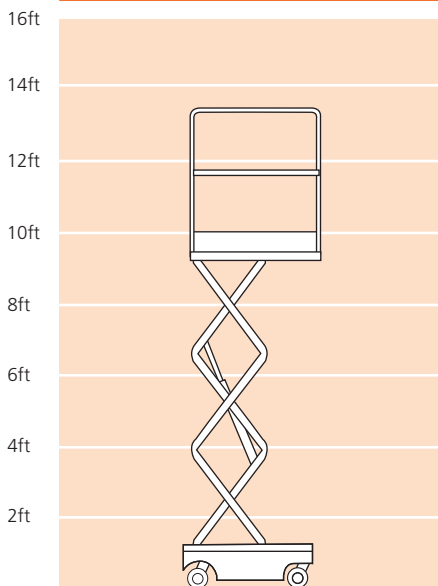

S3210P