

S3215L

LIGHTWEIGHT ELECTRIC SLAB SCISSOR LIFT



- Lightweight with low floor loadings
- Durable design for tough site conditions
- Drives through a standard doorway
- Easy to use and maintain
- Ideal for indoor & outdoor jobsites with floor load restrictions

 **snorkel**™
www.snorkellifts.com

LIGHTWEIGHT ELECTRIC SLAB SCISSOR LIFT

S3215L

DIMENSIONS	S3215L
Max. working height	21 ft
Max. platform height (A)	15 ft
Platform size	28.25 in x 73.5 in
Overall length (C) (with step)	81 in
Overall length (with step removed)	79.4 in
Overall width (D)	32 in
Stowed height (B)	75.25 in
Ground clearance (stowed)	2.5 in
Ground clearance (elevated)	0.75 in

PERFORMANCE	
Platform capacity (SWL)	670 lbs
Max. wind speed	28 mph
Max. drive height	15 ft
Max. drive speed (stowed)	2.0 mph
Max. drive speed (elevated)	0.4 mph
Raise/lower time	20/38 sec
Gradeability	25%
Inside turning radius	4 in
Outside turning radius	64.25 in
Tires	12 x 4 non-marking solid rubber
Controls	proportional
Drive system	2 wheel drive

POWER	
Power source	24V DC battery electric
Charger	120/240V

WEIGHT	
Weight	2,100 lbs
Floor load at max. capacity	195 psf

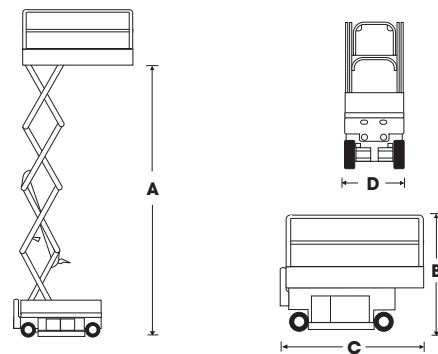

STANDARD FEATURES

- Aluminum platform
- Non-marking tires
- Swing-out service trays
- Saloon-door style entry gates
- Descent alarm
- All motion alarm
- 2 persons indoor
- 1 person outdoor
- Loading pendant
- Proportional controls, including descent
- Power line to platform
- Hour meter & on-board diagnostics display
- Integrated battery charger
- Battery condition indicator
- Crane & forklift points
- Dual lanyard attachments points
- Scissor stack roller slide plates (set of 2)
- 2 year parts & labor, 5 year structural warranty
- ANSI compliant

OPTIONS

- Special paint colors
- Flashing amber light
- Airline to platform
- Aircraft bumpguard package
- Environmental hydraulic oil
- Platform overload system
- Snorkel Guard™ secondary guarding system
- Platform overload system
- Inverter

TURNING RADIUS

