

QUICK SPECS

Weight	12,633 lbs
Horsepower	111.5 HP
Max Payload	8,379 lbs

Built for the toughest jobsites on Earth.



C50R-5

POWERFUL, EFFICIENT WATER-COOLED, 4-CYLINDER 111.5 HP TIER 4 FINAL DIESEL ENGINE

AUTOMATIC 2-SPEED HYDROSTATIC TRANSMISSION

TOUGH UNDERCARRIAGE FOR EXTREME CONDITIONS

IDEAL FOR STEEP SLOPES, SAND, SNOW & SWAMPY CONDITIONS

OPTIONAL ENCLOSED CAB WITH HEAT & A/C

OPTIONAL BARE-TYPE BED (NO DUMP BODY OR DUMP CYLINDER)

LARGE PLATFORM AND SUFFICIENT PTO TO SERVE AS MOUNTING VEHICLE FOR MULTIPLE ATTACHMENTS

Dump trucks are great, if they can get to the jobsite. But low ceilings, swampy or soft ground, snow and steep slopes can be obstacles to getting a job done. Not with the C50R. This durable, rubber-tracked, high-flotation, all-terrain carrier is right at home in conditions where others can't operate. Even in places where it's impossible or dangerous to turn, the seat and travel levers turn 180 degrees together so you're always moving forward. Take a seat. You'll quickly see that conditions don't decide whether a job gets done; only you do.

INNOVATIVE FEATURES



Neat, Easy Dumping For Tougher Conditions

With an ample 65-degree dumping angle and extended 2ft-2in distance from the dumping platform to the ground, you always get a sure and neat soil discharge with just a single dumping stroke. For even more versatility, add an optional 180-degree swivel dump loading platform for safe, efficient sideways dumping.



Reversible Seat and Travel Lever

The operator's seat and travel levers turn 180 degrees so the operator is always moving forward. This provides a safer work environment on mountain paths and other turn-restricted worksites. It also reduces damage to environmentally sensitive areas because there's no need to make skid turns.



Safe, Comfortable Cab

The operator's area is spacious and built for comfort. The C50 has been engineered for enhanced panoramic visibility from the operator's seat. The powerful 111.5 HP engine is also built for clean exhaust and quiet operation. Add an optional enclosed cab with heat and AC for year-round comfort.



C50R-5

Dimensions - C50R-5

THREE-WAY DUMP VESSEL

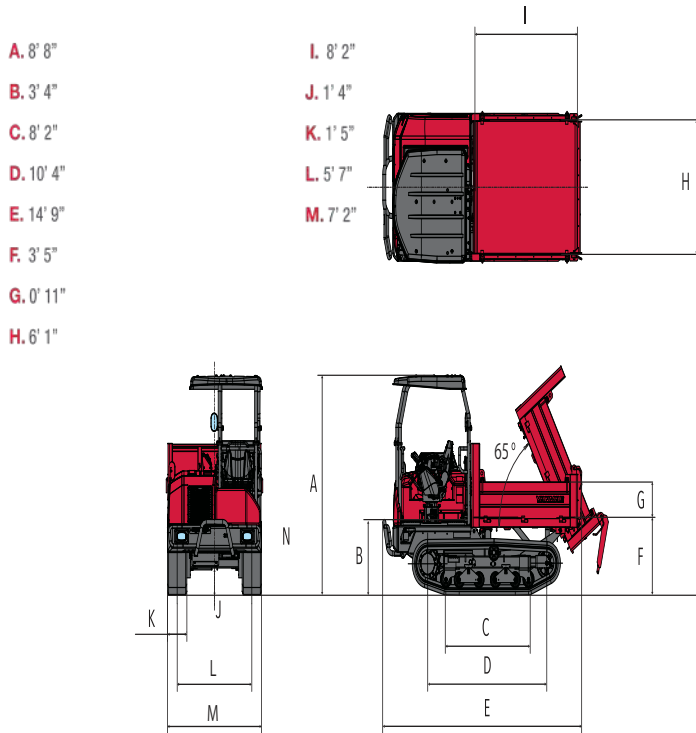

SWIVEL DUMP VESSEL

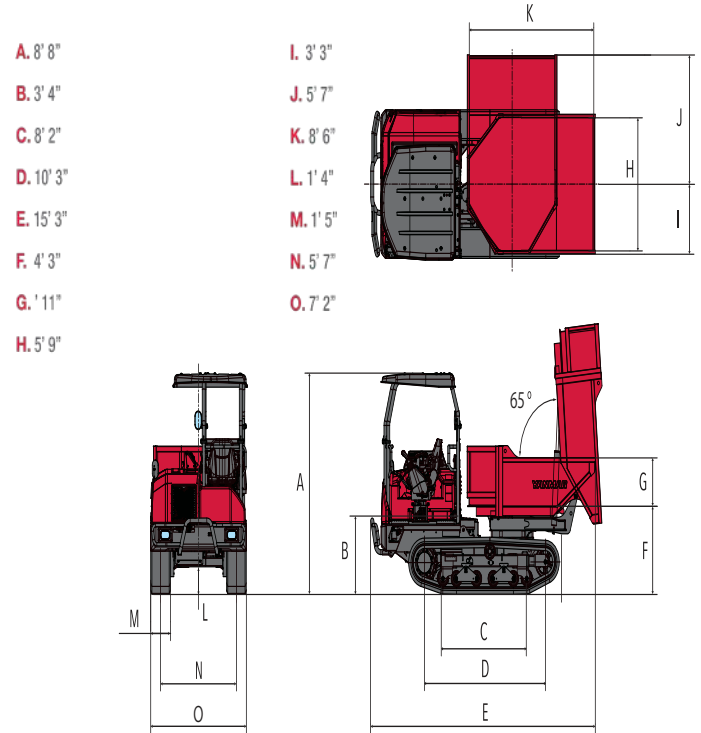

Model		C50R-5		C50R-5	
Dump vessel type		One-way dump type		Swivel-dump type	
Shape of Vessel		Box-shape		V shape	
Operating Weight	Net, unloaded	lbs (kg)	12,633 (5,730)		13,360 (6,060)
Engine	Type	-	Direct Injection Combustion Water-cooled 4-cyl. Diesel		
	Model	-	YANMAR 4TNV94FHT-NTBC		
	Output	HP (kW)	111.5 / 83.1		
Transmission	-	Variable Speed 2 Pump, 2 Motor Hydrostatic (HST)			
Undercarriage	Track Type	-	Steel-Reinforced Rubber Track		
	Track Width	ft-in (mm)	1'6" (450)		
	Min. Ground Clearance	ft-in (mm)	1'5" (435)		
	Ground Contact Pressure	w/o load	PSI (kPa)	3.4 (23.5)	
w/ load		PSI (kPa)	5.7 (39.5)		5.7 (39.5)
Performance	Max. Payload	lbs (kg)	8,379 (3,800)		7,718 (3,500)
	Max. Dumping Angle	degrees	65°		65°
	Dump Clearance	ft-in (mm)	2'2" (660)		2'11" (890)
	Dump Body Capacity	Struck yd³ (m³)	1.8 (1.4)		1.6 (1.2)
	Max. Travel Speed	mph (km/h)	5.9 (9.5)		5.9 (9.5)