

S2255RT/S2755RT

NARROW ROUGH TERRAIN SCISSOR LIFTS



- Narrow compact diesel rough terrain scissor lifts
- Excellent rough terrain performance
- Easy to operate
- Roll-out deck extension for extra reach
- Ideal for outdoor work in confined spaces

 **snorkel**[™]
www.snorkellifts.com

NARROW ROUGH TERRAIN SCISSOR LIFTS **S2255RT/** **S2755RT**

DIMENSIONS	S2255RT	S2755RT
Max. working height	27 ft 10 in	33 ft 1 in
Max. platform height (A)	21 ft 10 in	27 ft 1 in
Platform size (stowed)	4 ft 7 in x 8 ft 9 in	4 ft 7 in x 8 ft 9 in
Platform size (extended)	4 ft 7 in x 12 ft 8 in	4 ft 7 in x 12 ft 8 in
Extension deck length	3 ft 11 in	3 ft 11 in
Overall width (B)	4 ft 9 in	4 ft 9 in
Overall length (C)	10 ft 10 in	10 ft 10 in
Stowed height (D)	7 ft 8 in	8 ft 3 in
Min. height (guardrails folded)	6 ft 6 in	6 ft 11 in
Ground clearance	10.2 in	10.2 in

PERFORMANCE	S2255RT	S2755RT
Platform capacity (SWL)	925 lbs	660 lbs
Max. drive height	20 ft 4 in	25 ft 7 in
Max. wind speed	28 mph	28 mph
Max. drive speed (stowed)	3.2 mph	3.2 mph
Max. drive speed (elevated)	0.4 mph	0.3 mph
Raise/lower time	26/30 sec	26/30 sec
Gradeability	35%	35%
Max. stabilizer levelling, front to rear	6°	6°
Max. stabilizer levelling, side to side	10°	10°
Inside turning radius	8 ft 2 in	8 ft 2 in
Outside turning radius	15 ft 7 in	15 ft 7 in
Tires	23" x 8.9" - 12 non-marking	
Controls	proportional joystick	
Drive system	4 wheel drive	

POWER	S2255RT	S2755RT
Power source	Kubota diesel engine	

WEIGHT	S2255RT	S2755RT
Weight	5,313 lbs	6,062 lbs

TURNING RADIUS

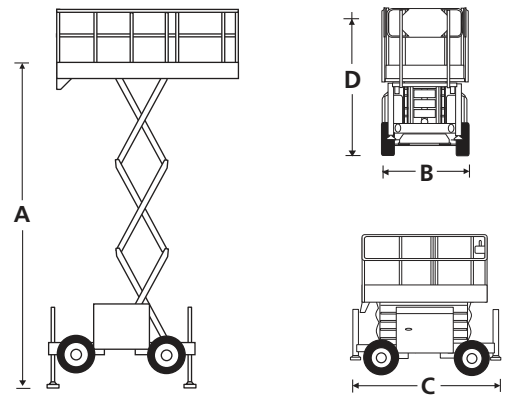
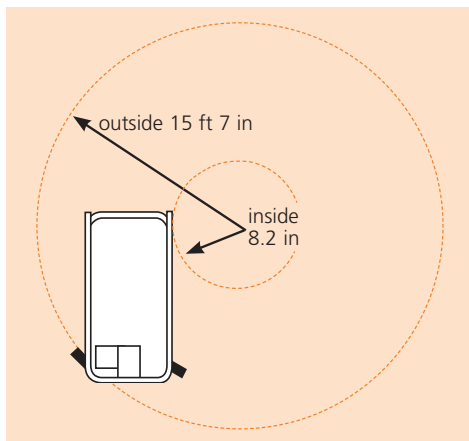

STANDARD FEATURES

- 4 wheel drive
- 4 hydraulic stabilizers with automatic leveling
- Roll-out deck extension
- Proportional controls
- Non-marking foam filled tires
- Power line to platform
- Drive motion alarm
- Descent alarm
- Articulating axle
- Manual lowering valve
- Flashing amber light
- Dual lanyard attachment points
- Hour meter
- 2 year parts & labor, 5 year structural warranty
- ANSI compliant

OPTIONS

- Special paint colors
- Nylon spreader pads (set of 4)
- Environmental hydraulic oil
- Cold weather package (block heater + battery warm-up)

snorkel www.snorkellifts.com

P.O. Box 1160
St. Joseph, MO 64502-1160, USA
Tel: 1 (785) 989-3000
Toll-free: 1 (800) 255-0317
Fax: 1 (785) 989-3070
Email: sales.usa@snorkellifts.com