

S9031RT-HC/S9043RT-HC

ULTRA HIGH CAPACITY ROUGH TERRAIN SCISSOR LIFTS



- Ultra high capacity, large deck rough terrain scissor lifts
- Excellent rough terrain performance
- Heavy duty design
- Dual powered extension decks
- Ideal for construction applications

 **snorkel**[™]
www.snorkellifts.com

ULTRA HIGH CAPACITY ROUGH TERRAIN SCISSOR LIFTS

S9031RT-HC/ S9043RT-HC

DIMENSIONS	S9031RT-HC*	S9043RT-HC*
Max. working height	37 ft	49 ft
Max. platform height (A)	31 ft	43 ft
Platform size (stowed)	16 ft x 7 ft 6 in	
Platform size (dual decks extended)	25 ft x 7 ft 6 in	
Extension deck length	4 ft 6 in	4 ft 6 in
Overall width (B)	7 ft 6 in	7 ft 6 in
Overall length (C)	16 ft	16 ft
Stowed height (D)	9 ft 1 in	9 ft 1 in
Min. height (guardrails folded)	6 ft 3 in	6 ft 3 in
Ground clearance	14 in	14 in

PERFORMANCE		
Platform capacity (SWL)	4,000 lbs	3,500 lbs
Max. drive height	31 ft	31 ft
Max. wind speed	28 mph	28 mph
Max. drive speed (stowed)	4.2 mph	4.2 mph
Max. drive speed (elevated)	0.6 mph	0.6 mph
Raise/lower time	30/20 sec	40/25 sec
Gradeability	50%	50%
Max. stabilizer levelling, front to rear	6°	6°
Max. stabilizer levelling, side to side	14°	14°
Inside turning radius	8 ft	8 ft
Outside turning radius	18 ft 6 in	18 ft 6 in
Tires	13 x 36 foam filled	
Controls	proportional joystick	
Drive system	4 wheel drive	

POWER	
Power source	Kubota diesel

WEIGHT		
Weight	15,000 lbs	17,000 lbs

TURNING RADIUS

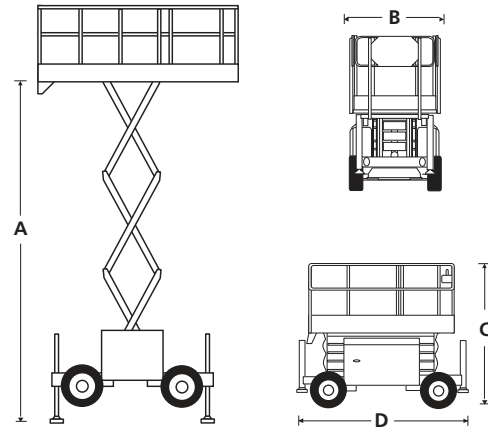
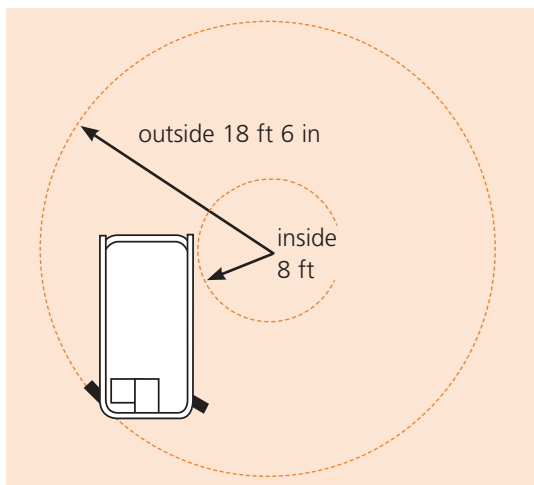

STANDARD FEATURES

- 4 wheel drive
- 4 hydraulic stabilizers with automatic levelling
- Dual powered extension decks
- Proportional controls
- Foam filled tires
- Power line to platform
- Drive motion alarm
- Descent alarm
- Locking articulating axle
- Fold-down guardrails
- Manual lowering valve
- Flashing amber light
- Dual lanyard attachment points
- Hour meter & on-board diagnostics display
- 2 year parts & labor, 5 year structural warranty
- ANSI compliant

OPTIONS

- Special paint colors
- Nylon spreader pads (set of 4)
- Environmental hydraulic oil
- Dual fuel
- LPG power
- Cold weather package (block heater + battery warm up)
- Hydraulic 2kW generator
- Hydraulic 12kW generator

snorkel www.snorkellifts.com

P.O. Box 1160
St. Joseph, MO 64502-1160, USA
Tel: 1 (785) 989-3000
Toll-free: 1 (800) 255-0317
Fax: 1 (785) 989-3070
Email: sales.usa@snorkellifts.com